



Micro Detectors



Italian Sensors Technology

PRODUCT CATALOGUE
ENCODER

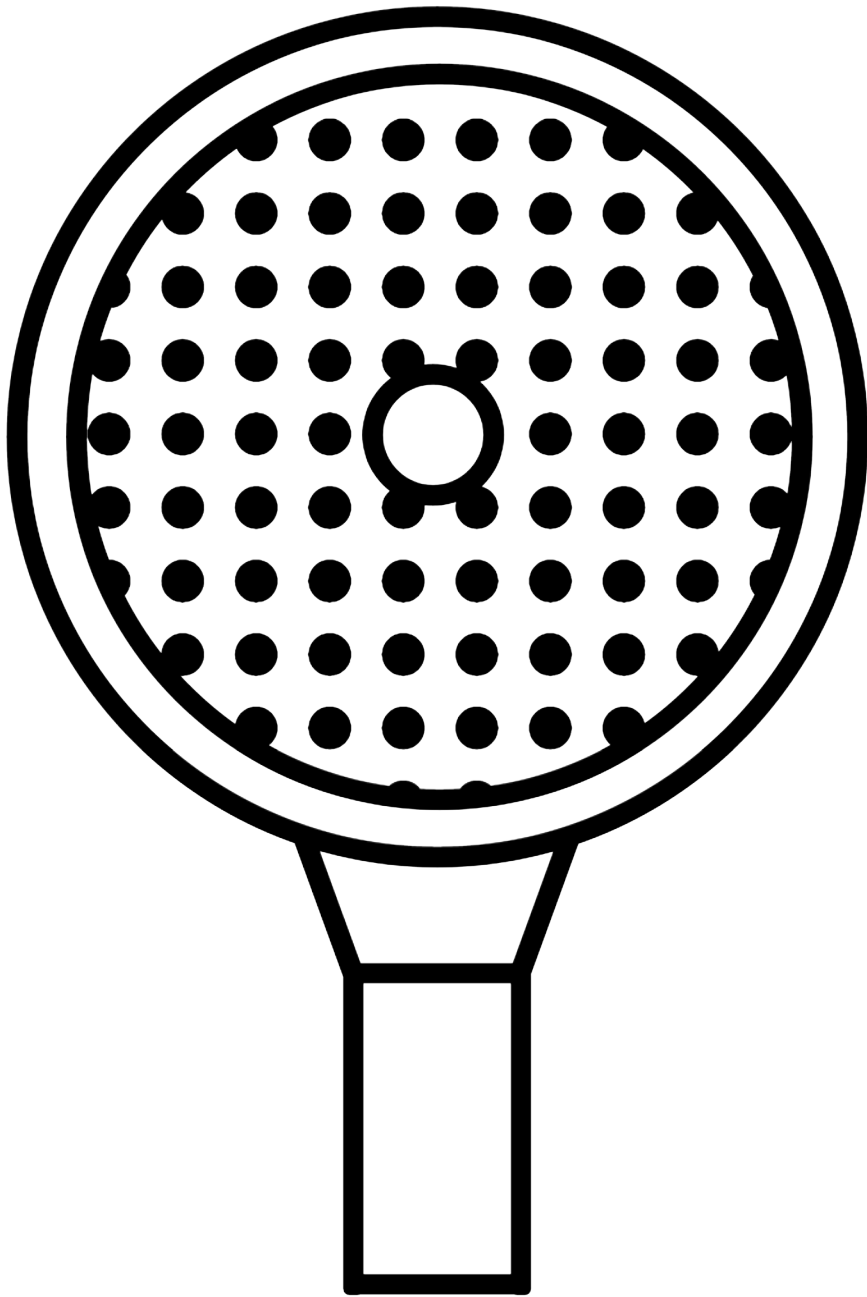



Working principle

An encoder is a rotary transducer that converts an angular movement into a series of electrical digital pulses. If associated to racks or endless screws, these generated pulses can be used to control angular or linear movements. During rotation, electrical signals can be elaborated by numerical controls (CNC), programmable logic controls (PLC), control systems, etc. Main applications of these transducers are: machinery, robots, motor feedback, measure and control devices. In M.D. Micro Detectors encoders the angular movement transduction is based on the photo-electric scanning principle. The reading system is based on the rotation of a radial graduated disk formed by opaque windows and transparent ones alternated. The system is perpendicularly illuminated by an infrared light source. The light projects the disk image on the receivers surface which are covered by a grating called collimator having the same disk steps. The receivers transduce the occurring light variations caused by the disk shifting and convert them into their corresponding electrical variations. Electrical signals, raised to generate squared pulses without any interference, must be electronically processed. The reading system is always carried out in differential modality, that is comparing different signals nearly identical but out of phase of 180 electrical degrees. That in order to increase quality and stability of output signals. The reading is performed comparing the difference between the two channels, to remove the noise known as "common mode", because signals are overlapped in equal way on each wave.

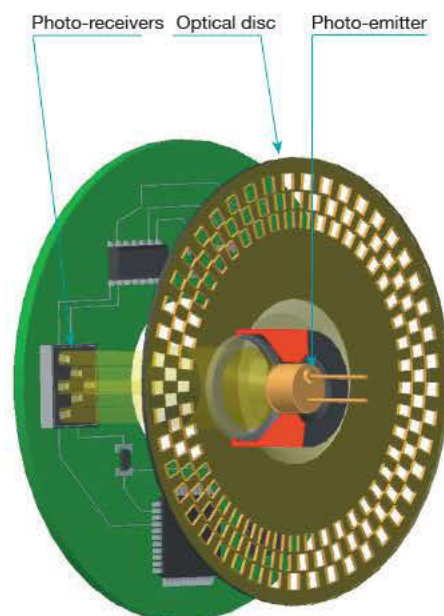

Incremental encoder

The incremental encoder usually gives two types of squared waves out of phase of 90 electrical degrees. They are usually called channel A and B. The first channel gives information about the rotation speed while the second, basing on the state sequence produced by the two signals, provides the direction of rotation. A further signal, called Z or zero channel, is also available. It gives the absolute zero position of the encoder shaft. This signal is a squared pulse with phase and width centered on A channel.

The incremental encoder accuracy depends on mechanical and electrical factors. These errors could be: grating division, disk eccentricity, bearings eccentricity, electronic reading and optical inaccuracy. The measurement unit to define encoder accuracy is the electrical degree. It determines the division of the impulse generated by the encoder: 360 electrical degrees correspond to the mechanical rotation of the shaft which is necessary to carry out a complete cycle. To know how many mechanical degrees correspond to 360 electrical degrees the following formula has to be applied:

$$\text{electrical } 360^\circ = \frac{\text{mechanical } 360^\circ}{\text{nr. pulses / turn}}$$

The encoder division error is given from the maximum shifting shown in the electrical degrees of two consecutive edges. This error exists in any encoder and is due to the above mentioned factors.

On M.D. Micro Detectors encoders pulse error is $\pm 18^\circ$ e max. on full operating range, which corresponds to a $\pm 10\%$ from nominal value.

Regarding the 90 electrical degrees phase relation between the two channels, it differs in ± 35 electrical degrees max which corresponds to $\pm 10\%$ respect to signal period.

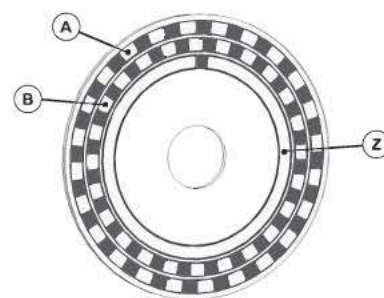

CLOCKWISE ROTATION DIRECTION

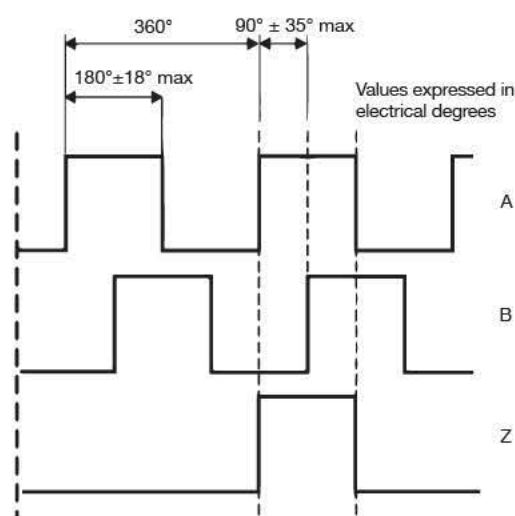

Graphic representation of A, B and Z incremental signals.



notes

A series of 20 horizontal light blue bars, evenly spaced, providing a template for writing notes.



MDI 40 A series

Miniaturized \varnothing 42 mm encoder series for general factory automation applications



Miniaturized \varnothing 42 mm encoder

features

- 3 channel encoder (A / B / Z) up to 2500 ppr
- Power supply up to +30 VDC with several electronic outputs available
- Up to 220 kHz output frequency
- Cable output, connectors available on cable end
- 6 mm solid shaft diameter
- Mounting by clamping flange



web contents



- Application notes
- Photos
- Catalogue / Manuals



code description

	MDI	40A	500	Z	5/30	L	6	X	X	P	R
series	MDI	incremental encoder series MDI									
model	40A	clamping flange \varnothing 20 mm									
resolution	D	ppr 100 ... 2500 mm									
zero pulse	S	without zero pulse									
	Z	with zero pulse									
power supply	5/30	5...30 Vdc									
electronic interference	P	push-pull									
	L	line driver									
	RS	power supply 5/30V - output RS-422									
shaft diameter	6	6 mm									
enclosure rating	X	IP54									
	S	IP66									
option	X	to be reported									
output type	P	cable (standard length 0.5 m)*									
direction type	R	radial									

* Longer cable available on demand



technical specifications

Miniaturized Ø42 mm encoder

	MDI 40
shaft diameter	ø 6 mm
IP mechanical protection	X = IP 54 (IEC 60529) S = IP 66 (IEC 60529)
max rotation speed	3000 rpm (IP 66) 6000 rpm (IP 54)
max shaft load	5 N axial / radial
shock resistance	50 G, 11 ms (IEC 60068-2-27)
vibration resistance	10 G, 10 ... 2000 Hz (IEC 60068-2-6)
moment of inertia	0,1 x 10 ⁻⁶ kgm ²
starting torque (at +20°C / +68°F)	< 0,01 Nm (IP 54) < 0,05 Nm (IP 66)
body material	EN-AW 2011 aluminum
shaft material	1.4305 / AISI 303 stainless steel
housing material	PA66 glass fiber reinforced
bearings	2 ball bearings
bearings life	10 ⁹ revolutions
operating temperature	-25° ... +85°C (-13° ... +185°F)
storage temperature	-25° ... +70°C (-13° ... +158°F)
weight	100 g (3,52 oz)
resolution	from 100 to 2500 ppr
power supply	5/30 = 4,5 ... 30 V DC (reverse polarity protection)
No-Load supply current	800 mW
max load current	20 mA / channel
output type*	push-pull / line driver
max output frequency	220 kHz
counting direction	A leads B clockwise (shaft view)
EMC	IEC 61000-6-2 IEC 61000-6-4

* output levels according to power supply

connections

function	Cable output Push pull	Cable output Line driver
+V DC	red	red
0 V	black	black
Ch. A	green	green
Ch. A-	/	brown
Ch. B	yellow	yellow
Ch. B-	/	orange
Ch. Z	blue	blue
Ch. Z-	/	white
\perp	shield	shield

resolutions

MDI 40 A

100* - 120 - 128 - 150* - 200* - 240 - 250 - 256 - 300* - 360* - 400* - 480 - 500* - 512* - 600* - 625 - 720* - 750 -
800 - 900 - 1000* - 1024* - 1200* - 1250 - 1440* - 1500 - 1600 - 1800 - 2000* - 2048* - 2500

* preferred resolutions





dimensions (mm)

MDI 40 A IP54

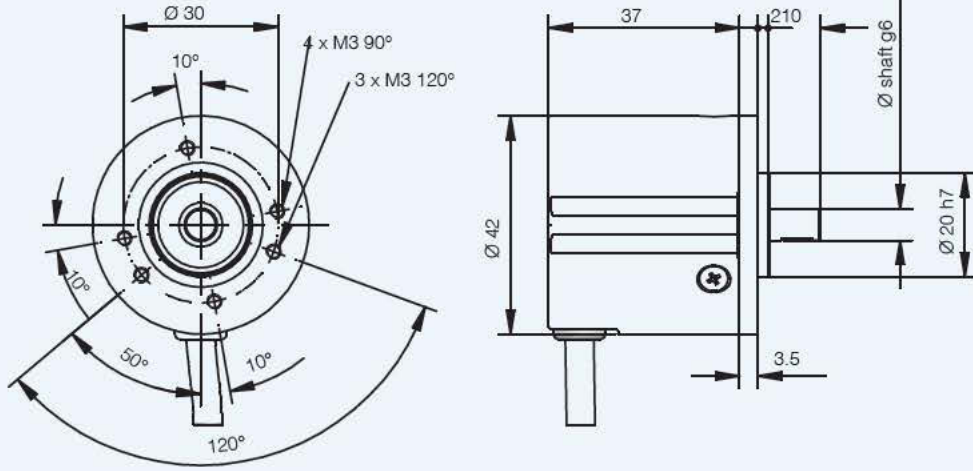

MDI 40 A IP66

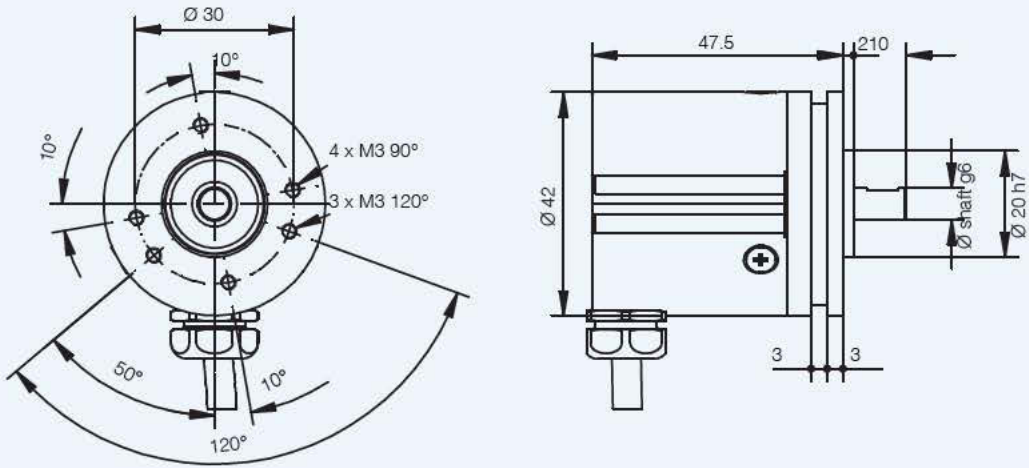



MDI 58 B / C series

Standard Ø 58 mm encoder series for industrial applications with high mechanical resistance requirements



Standard Ø 58 mm encoder

features

- 3 channel encoder (A / B / Z) up to 2500 ppr
- Power supply up to +30 VDC with several electronic outputs available
- Up to 220 kHz output frequency
- Cable or connector output
- Solid shaft diameter up to 10 mm
- Mounting by synchronous, clamping flange



web contents



- Application notes
- Photos
- Catalogue / Manuals



code description

	MDI	58B	1000	Z	5/30	P	6	X	X	P	R
series	MDI	incremental encoder series MDI									
model	58B	synchronous flange Ø 50 mm									
	58C	clamping flange Ø 36 mm									
resolution	D	ppr 100 ... 2500 mm									
zero pulse	S	without zero pulse									
	Z	with zero pulse									
power supply	5/30	5...30 Vdc									
electronic interference	P	push-pull									
	L	line driver									
	RS	power supply 5/30V - output RS-422									
shaft diameter	6	mod. B - mm 6									
	10	mod. C - mm 10									
enclosure rating	X	IP54									
	S	IP66									
option	X	to be reported									
output type	P	cable (standard length 1.5 m)*									
	M	MIL connector									
	M12	M12 connector									
direction type	A	axial									
	R	radial									

* Longer cable available on demand



Standard Ø 58 mm encoder

technical specification

MDI 58 B/C	
shaft diameter	ø 6 mod.B ø 10 mm mod.C
IP mechanical protection	X = IP 54 (IEC 60529) S = IP 66 (IEC 60529)
max rotation speed	6000 rpm (IP54) 3000 rpm / 70° C - 2000 rpm / 85° C (IP66)
max shaft load	10 N axial with ø6 mm shaft 20 N radial with ø6 mm shaft 200 N axial / radial
shock resistance	50 G, 11 ms (IEC 60068-2-27)
vibration resistance	10 G, 10 ... 2000 Hz (IEC 60068-2-6)
moment of inertia	1,5 x 10 ⁻⁶ kgm ²
starting torque (at +20°c / +68°f)	< 0,02 Nm (IP 54) < 0,06 Nm (IP 66)
body material	EN-AW 2011 aluminum
shaft material	1.4305 / AISI 303 stainless steel
housing material	PA66 glass fiber reinforced
bearings	2 ball bearings
bearings life	10 ⁹ revolutions
operating temperature	-25° ... +85°C (-13° ... +185°F)
storage temperature	-25° ... +70°C (-13° ... +158°F)
weight	350 g (12,35 oz)
resolution	from 100 to 2500 ppr
power supply	5/30 = 4,5 ... 30 V DC (reverse polarity protection)
No-Load supply current	800 mW
max load current	20 mA / channel
output type*	push-pull / line driver
max output frequency	220 kHz
counting direction	A leads B clockwise (shaft view)
EMC	IEC 61000-6-2 IEC 61000-6-4

* output levels according to power supply

resolutions

MDI 58 B/C
100* - 120 - 128 - 150 - 200 - 240 - 250 - 256 - 300 - 360* - 400* - 480 - 500* - 512* - 600* - 625 - 720* - 750 - 800 - 900 - 1000* - 1024* - 1200 - 1250 - 1440 - 1500 - 1600 - 1800 - 2000* - 2048* - 2500*

* preferred resolutions

function	Cable output Push pull	Cable output Line driver	7 pin M output Push pull	7 pin M output Line Driver no Zero	10 pin M output Line Driver with Zero	5 pin M12 output Push pull	8 pin M12 output Line Driver
+V DC	red	red	F	D	D - E	2	7
0 V	black	black	A	F	F	4	1
Ch. A	green	green	C	A	A	3	6
Ch. A-	/	brown	/	C	G	/	5
Ch. B	yellow	yellow	E	B	B	1	4
Ch. B-	/	orange	/	E	H	/	3
Ch. Z	blue	blue	D	/	C	5	2
Ch. Z-	/	white	/	/	I	/	8
⊥	shield	shield	G	G	J	housing	housing

M connector (7 pin)
Amphenol MS3102-E-16-S
solder side view FV



M connector (10 pin)
Amphenol MS3102-E-18-1
solder side view FV



M connector (5 pin)
M12 A coded
solder side view FV

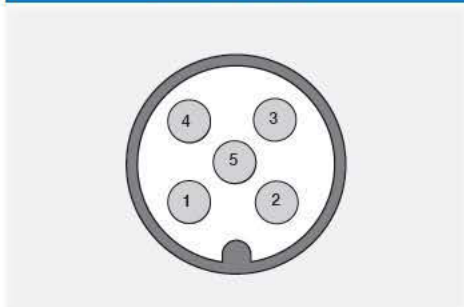

M connector (8 pin)
M12 A coded
solder side view FV

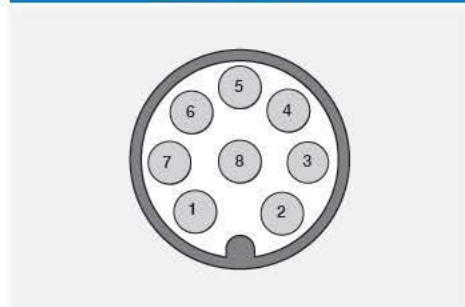



dimensions (mm)

MDI 58 B

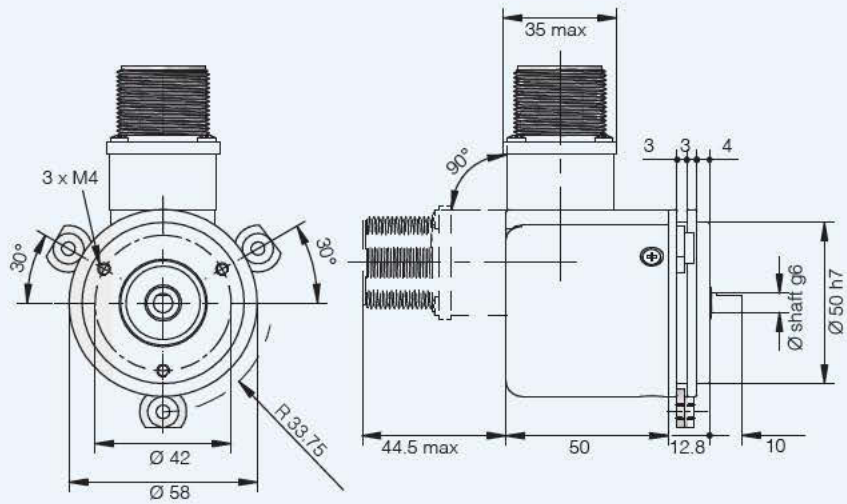

MDI 58 C

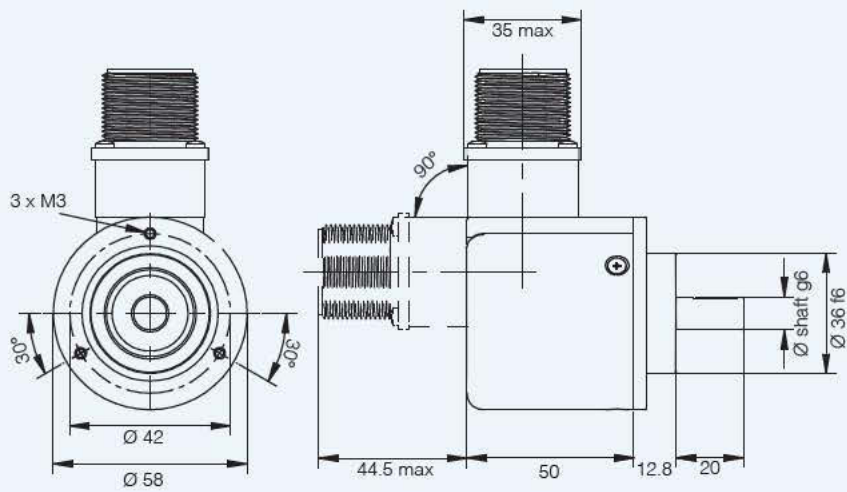

dimensions (mm)

set n.3 fixing clamps for model 58 B

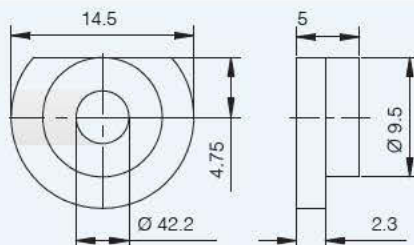



MDI 63 A / D series

Standard ø 63 mm encoder series for industrial applications with high mechanical resistance requirements



Standard Ø 63 mm encoder

features

- 3 channel encoder (A / B / Z) up to 2500 ppr
- Power supply up to +30 VDC with several electronic outputs available
- Up to 220 kHz output frequency
- Cable or connector output
- Solid shaft diameter up to 10 mm
- Mounting by synchronous or centering 2,5" square flange



web contents



- Application notes
- Photos
- Catalogue / Manuals



code description

	MDI	63A	1000	Z	5/30	P	9	X	X	M	R
series	MDI	incremental encoder series MDI									
model	63A	synchronous flange ø 31.75 mm									
	63D	centering square flange ø 31.75 mm									
resolution	D	ppr 100 ... 2500 mm									
zero pulse	S	without zero pulse									
	Z	with zero pulse									
power supply	5/30	5...30 Vdc									
electronic interference	P	push-pull									
	L	line driver									
	RS	power supply 5/30V - output RS-422									
shaft diameter	9	9,52 (3/8") mm									
	10	10 mm									
enclosure rating	X	IP54									
	S	IP66									
option	X	to be reported									
output type	P	cable (standard length 1.5 m)*									
	M	MIL connector									
	M12	M12 connector									
direction type	A	axial									
	R	radial									

* Longer cable available on demand

Standard \varnothing 63 mm
encoder

technical specification

MDI 63 A / D	
shaft diameter	\varnothing 9,52 (3/8") / 10 mm
IP mechanical protection	X = IP 54 (IEC 60529) S = IP 66 (IEC 60529)
max rotation speed	6000 rpm (IP54) 3000 rpm / 70° C - 2000 rpm / 85° C (IP66)
max shaft load	200 N
shock resistance	50 G, 11 ms up to 2500 ppr (IEC 60068-2-27)
vibration resistance	10 G, 10 ... 2000 Hz (IEC 60068-2-6)
moment of inertia	$1,5 \times 10^{-6}$ kgm ²
starting torque (at +20°C / +68°F)	< 0,02 Nm (IP 54) < 0,06 Nm (IP 66)
body material	EN-AW 2011 aluminum
shaft material	1.4305 / AISI 303 stainless steel
housing material	PA66 glass fiber reinforced
bearings	2 ball bearings
bearings life	10 ⁹ revolutions
operating temperature	-25° ... +85°C (-13° ... +185°F) ER series
storage temperature	-25° ... +70°C (-13° ... +158°F)
weight	350 g (12,35 oz)
resolution	from 100 to 2500 ppr
power supply	5/30 = 4,5 ... 30 V DC (reverse polarity protection)
No-Load supply current	800 mW
max load current	20 mA / channel
output type*	push-pull / line driver
max output frequency	220 kHz
counting direction	A leads B clockwise (shaft view)
EMC	IEC 61000-6-2 IEC 61000-6-4

* output levels according to power supply

resolutions

MDI 63 A / D
100* - 120 - 128 - 150 - 200 - 240 - 250 - 256 - 300 - 360* - 400 - 480 - 500* - 512* - 600* - 625 - 720* - 750 - 800 - 900 - 1000* - 1024* - 1200 - 1250 - 1440 - 1500 - 1600 - 1800 - 2000* - 2048* - 2500*

* preferred resolutions

function	Cable output Push pull	Cable output Line driver	7 pin M output Push pull	7 pin M output Line Driver no Zero	10 pin M output Line Driver with Zero	5 pin M12 output Push pull	8 pin M12 output Line Driver
+V DC	red	red	F	D	D - E	2	7
0 V	black	black	A	F	F	4	1
Ch. A	green	green	C	A	A	3	6
Ch. A-	/	brown	/	C	G	/	5
Ch. B	yellow	yellow	E	B	B	1	4
Ch. B-	/	orange	/	E	H	/	3
Ch. Z	blue	blue	D	/	C	5	2
Ch. Z-	/	white	/	/	I	/	8
⊥	shield	shield	G	G	J	housing	housing

M connector (7 pin)
Amphenol MS3102-E-16-S
solder side view FV

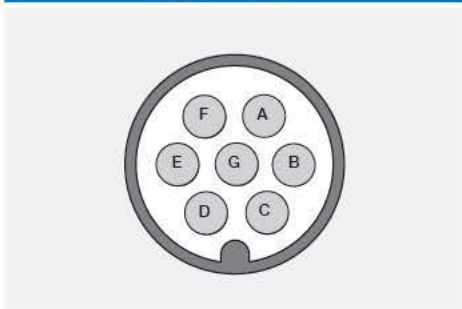

M connector (10 pin)
Amphenol MS3102-E-18-1
solder side view FV

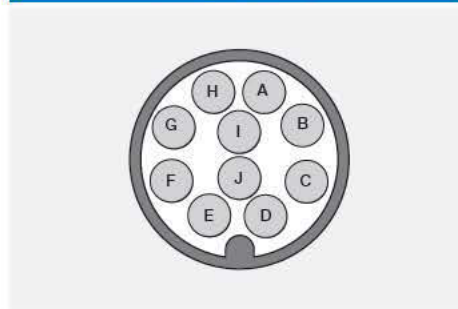

M12 connector (5 pin)
M12 A coded
solder side view FV

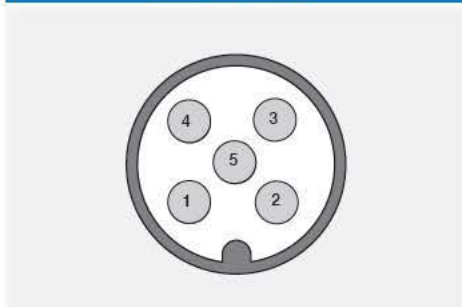

M12 connector (8 pin)
M12 A coded
solder side view FV

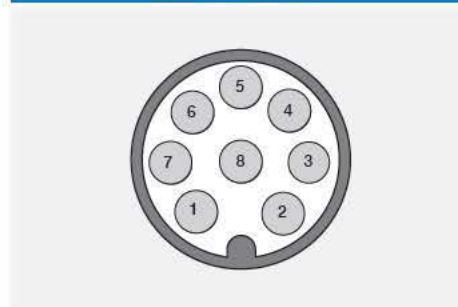



dimensions (mm)

MDI 63 A

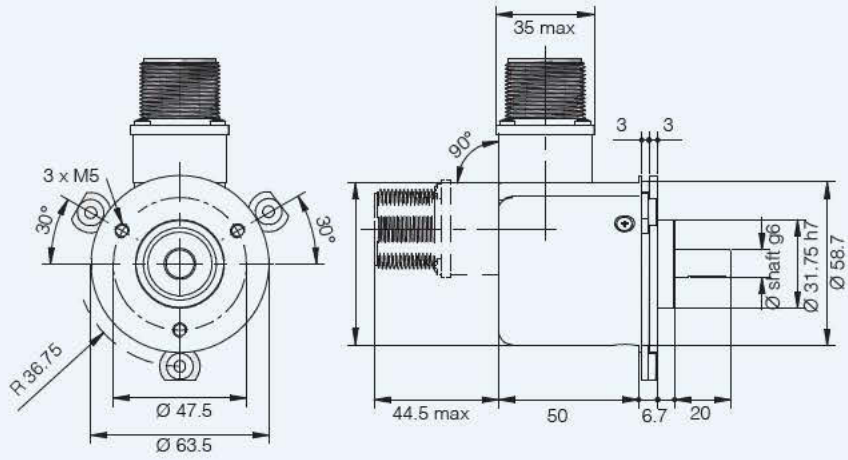

MDI 63 D

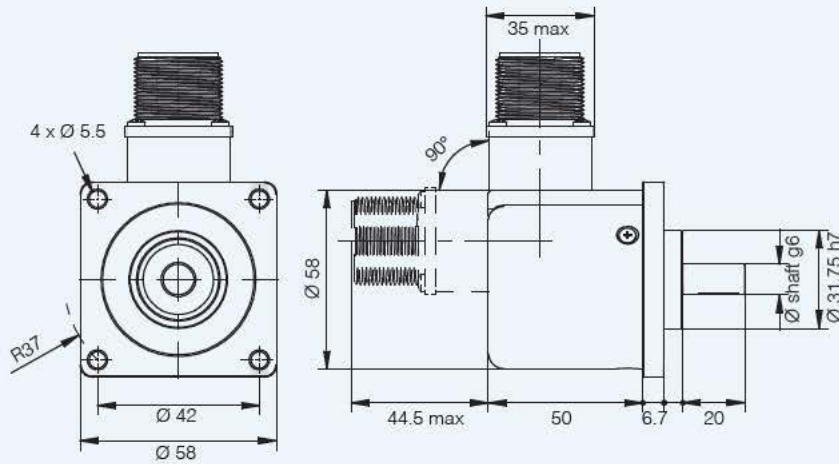

dimensions (mm)

set n.3 fixing clamps for model 63A

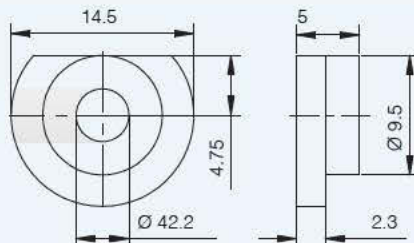



MDI 38 F / G series

Miniaturized ø 38 encoder series for general factory automation applications, small AC motors and gearmotors.



Miniaturized Ø 38 mm encoder

features

- 3 channel encoder (A / B / Z) up to 2500 ppr
- Power supply up to +30 VDC with several electronic outputs available
- Up to 220 kHz output frequency
- Cable output, connectors available on cable end
- Metal cover for high IP mechanical protection
- Blind hollow shaft diameter up to 10 mm
- Mounting by stator coupling or anti-rotation pin



web contents



- Application notes
- Photos
- Catalogue / Manuals



code description

	MDI	38F	1024	Z	5/30	P	6	X	X	PR
series	MDI	incremental encoder series MDI								
model	38F	blind hollow shaft with stator coupling								
	38G	blind hollow shaft with anti-rotation pin								
resolution	D	ppr 100 ... 2500 mm								
zero pulse	S	without zero pulse								
	Z	with zero pulse								
power supply	5/30	5...30 Vdc								
electronic interference	P	push-pull								
	L	line driver								
	RS	power supply 5/30V - output RS-422								
bore diameter	6	6 mm								
	8	8 mm								
	10	10 mm								
enclosure rating	X	IP64								
	S	IP65								
option	X	to be reported								
	PR	radial cable (standard length 0.5 m)*								

* Longer cable available on demand



technical specification

MDI 38 F / G	
bore diameter	\varnothing 6* / 8* / 10 mm
IP mechanical protection	IP 64 (IEC 60529) IP 65 (IEC 60529)
max rotation speed	3000 rpm
max shaft load	5 N axial / radial
shock resistance	50 G, 11 ms (IEC 60068-2-27)
vibration resistance	10 G, 10 ... 2000 Hz (IEC 60068-2-6)
moment of inertia	$0,8 \times 10^{-6}$ kgm ²
starting torque (at +20°C / +68°F)	< 0,01 Nm (IP 64) < 0,06 Nm (IP 65)
body material	EN-AW 2011 aluminum
shaft material	1.4305 / AISI 303 stainless steel
housing material	painting aluminum
bearings	2 ball bearings
bearings life	10 ⁹ revolutions
operating temperature	-20° ... +70°C
storage temperature	-25° ... +70°C
weight	150 g
resolution	from 100 to 2500 ppr
power supply	5/30 = 4,5 ... 30 V DC (reverse polarity protection)
No-Load supply current	800 mW
max load current	20 mA / channel
output type**	push-pull / line driver
max output frequency	220 kHz
counting direction	A leads B clockwise (shaft view)
EMC	IEC 61000-6-2 IEC 61000-6-4

* with supplied adapter shaft

** output levels according to power supply



function	Cable output Push pull	Cable output Line driver
+V DC	red	red
0 V	black	black
Ch. A	green	green
Ch. A-	/	brown
Ch. B	yellow	yellow
Ch. B-	/	orange
Ch. Z	blue	blue
Ch. Z-	/	white
⊥	shield	shield

resolutions

MDI 38 F / G

100* - 120 - 128 - 200 - 240 - 256 - 360* - 400 - 480 - 500* - 512* - 625 - 720 -
750 - 900 - 1000* - 1024* - 1250 - 1440 - 1500 - 1800 - 2000* - 2048* - 2500*

* preferred resolutions



MDI 38 F

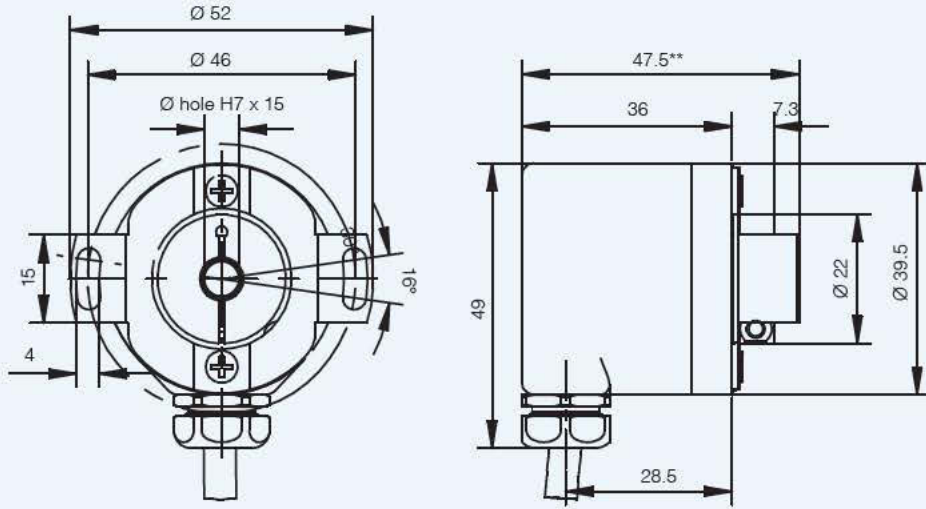

** IP65 + 5.2

MDI 38 G

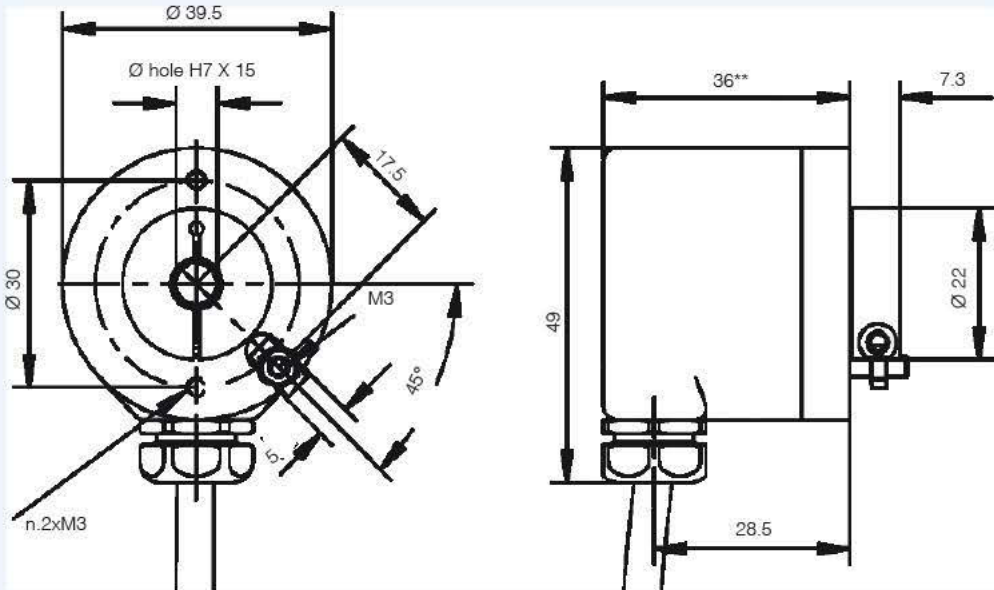

** IP65 + 5.2

*anti-rotation pin is included in model G, for mounting instruction please refer to product installation notes



MDI 58 F / G - 63 F / G series

Hollow shaft encoder series for industrial applications with high mechanical resistance requirements.



Hollow shaft encoder series

features

- 3 channel encoder (A / B / Z) up to 2500 ppr
- Power supply up to +30 VDC with several electronic outputs available
- Up to 220 kHz output frequency
- Cable or connector output
- Blind hollow shaft diameter up to 15 mm
- Mounting by stator coupling, spring or anti-rotation pin



web contents



- Application notes
- Photos
- Catalogue / Manuals



code description

	MDI	58G	1000	Z	5/30	P	10	X	X	M	R	
series	MDI	incremental encoder series MDI										
model	58F	blind hollow shaft with stator coupling										
	58G	blind hollow shaft with anti-rotation pin										
	63F	blind hollow shaft with spring										
	63G	blind hollow shaft with anti-rotation pin										
resolution	1000	ppr 100 ... 2500 mm										
zero pulse	S	without zero pulse										
	Z	with zero pulse										
power supply	5/30	5...30 Vdc										
electronic interference	P	push-pull										
	L	line driver										
	RS	power supply 5/30V - output RS-422										
bore diameter	10	10 mm										
	15	15 mm										
enclosure rating	X	IP54										
	S	IP66										
option	X	to be reported										
output type	P	cable (standard length 1.5 m)*										
	M	MIL connector										
	M12	M12 connector										
direction type	A	axial										
	R	radial										

* Longer cable available on demand



technical specification

MDI 58 F / G - 63 F / G	
bore diameter	∅ 10 / 15 mm
IP mechanical protection	X = IP 54 (IEC 60529) S = IP 66 (IEC 60529)
max rotation speed	3000 rpm
max shaft load	200 N
shock resistance	50 G, 11 ms up to 2500 ppr (IEC 60068-2-27)
vibration resistance	10 G, 10 ... 2000 Hz (IEC 60068-2-6)
moment of inertia	4 x 10 ⁻⁶ kgm ²
starting torque (at +20°C / +68°F)	< 0,02 Nm (IP 54) < 0,06 Nm (IP 66)
Fixing torque for collar clamping	1 Nm max
body material	EN-AW 2011 aluminum
shaft material	1.4305 / AISI 303 stainless steel
housing material	PA66 glass fiber reinforced
bearings	2 ball bearings
bearings life	10 ⁹ revolutions
operating temperature	-20° ... +70°C (-4° ... +158°F)
storage temperature	-25° ... +70°C (-13° ... +158°F)
weight	350 g (12,35 oz)
resolution	from 100 to 2500 ppr
power supply	5/30 = 4,5 ... 30 V DC (reverse polarity protection)
No-Load supply current	800 mW
max load current	20 mA / channel
output type*	push-pull / line driver
max output frequency	220 kHz
counting direction	A leads B clockwise (shaft view)
EMC	IEC 61000-6-2 IEC 61000-6-4

* output levels according to power supply

resolutions

MDI 58 F / G - 63 F / G
100* - 120 - 128 - 200 - 240 - 256 - 360* - 400 - 480 - 500* - 512* - 625 - 720* - 750 - 900 - 1000* - 1024* - 1250 - 1440 - 1500 - 1800 - 2000* - 2048* - 2500*

* preferred resolutions



function	Cable output Push pull	Cable output Line driver	7 pin M output Push pull	7 pin M output Line Driver no Zero	10 pin M output Line Driver with Zero	5 pin M12 output Push pull	8 pin M12 output Line Driver
+V DC	red	red	F	D	D - E	2	7
0 V	black	black	A	F	F	4	1
Ch. A	green	green	C	A	A	3	6
Ch. A-	/	brown	/	C	G	/	5
Ch. B	yellow	yellow	E	B	B	1	4
Ch. B-	/	orange	/	E	H	/	3
Ch. Z	blue	blue	D	/	C	5	2
Ch. Z-	/	white	/	/	I	/	8
⊥	shield	shield	G	G	J	housing	housing

M connector (7 pin)
Amphenol MS3102-E-16-S
solder side view FV

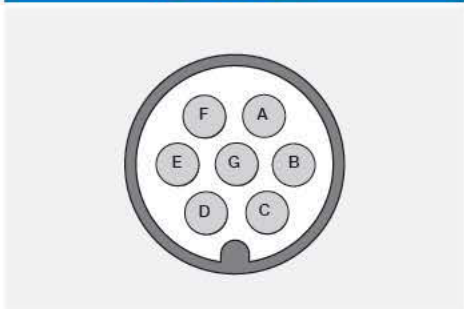

M connector (10 pin)
Amphenol MS3102-E-18-1
solder side view FV

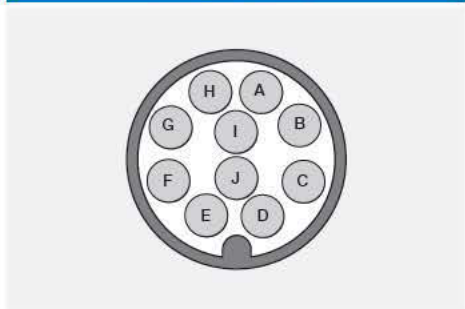

M12 connector (5 pin)
M12 A coded
solder side view FV

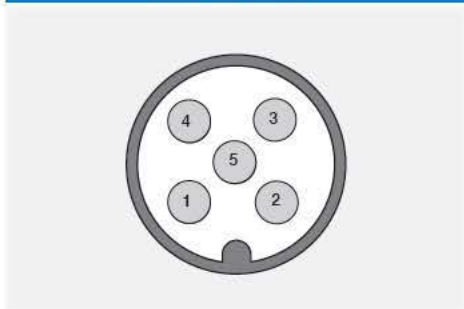

M12 connector (8 pin)
M12 A coded
solder side view FV

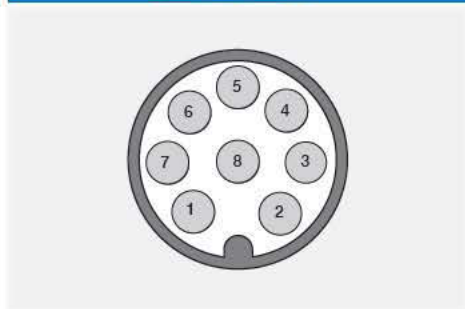



dimensions (mm)

MDI 58 F

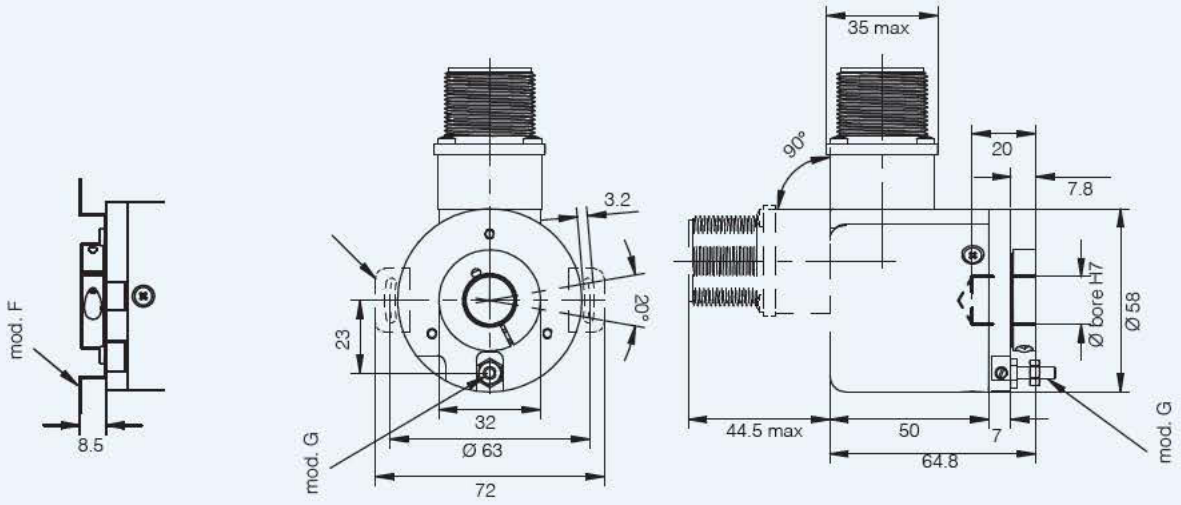

MDI 58 G

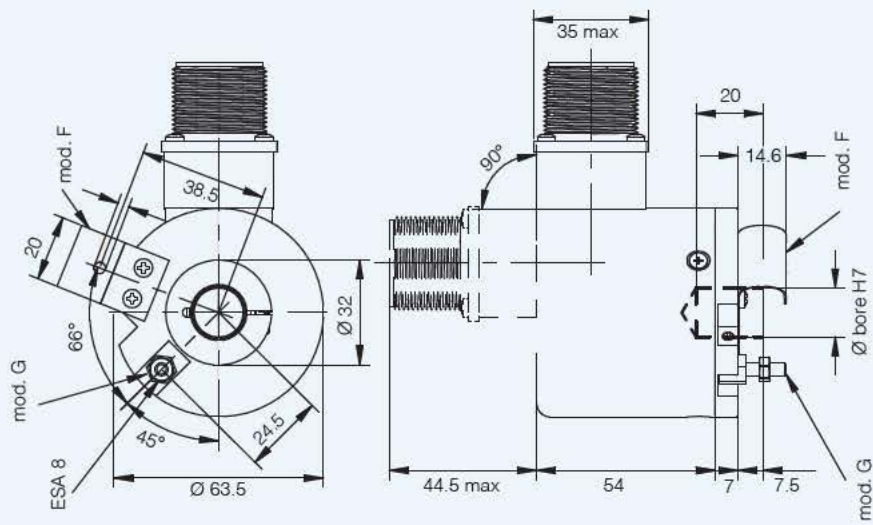

anti-rotation pin is included in model G, for mounting instruction please refer to product installation notes



Elastic Couplings

Essential parts for motion transmission to the encoder shaft.

- aluminium alloy made
- composed by a cylindrical body on which there is a helical groove that determines:
 - torsional rigidity
 - ability to compensate for slight shaft misalignments
 - ability to absorb shaft axial play
- supplied with different coupling diameters

code description

	MDG	25	A	6	/8
series	MDG	precision elastic coupling			
model	20	(see table) 20			
	25	(see table) 25			
	30	(see table) 30			
shaft fixing type	A	shaft fixing with grub screw			
hole diameter d1	6	ø 6 mm			
	8	(mod. G25 / G30) ø 8 mm			
	9	ø 9,52 (3/8") mm			
	10	ø 10 mm			
hole diameter d2 (do not add if d2 = d1)	6	ø 6 mm			
	8	(mod. G25 / G30) ø 8 mm			
	9	ø 9,52 (3/8") mm			
	10	ø 10 mm			



Encoder
Accessories

dimensions (mm)

Elastic Couplings

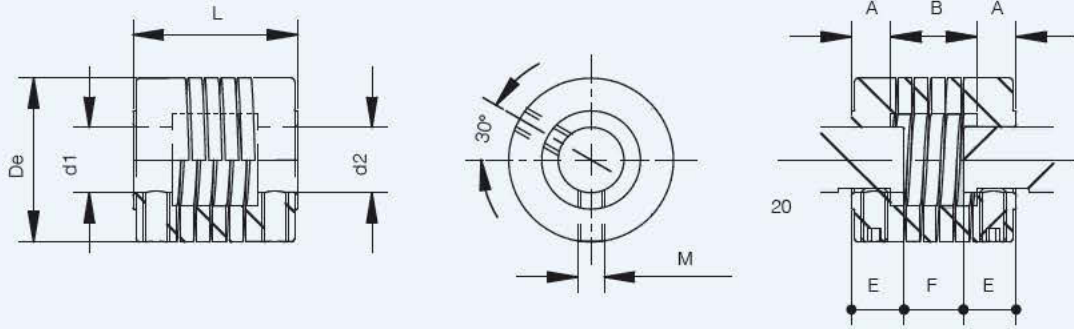

standard couplings

Type of material:
aluminium

For other holes (d1-d2)
contact our office
directly



standard couplings	D_e	L	$d_1 = d_2$		A	B	M	E	F	Torque	
MDG 20 A 6	$\varnothing 20$	20	$+0.1$ -0.1	$\varnothing 6H7$	$+0.012$ 0	6	8	M3	7	6	0.25 Nm
MDG 25 A 8	$\varnothing 25$	25	$+0.1$ -0.1	$\varnothing 8H7$	$+0.015$ 0	7	11	M4	8	9	0.4 Nm
MDG 25 A 9	$\varnothing 25$	25	$+0.1$ -0.1	$\varnothing 9,52H7$	$+0.015$ 0	7	11	M4	8	9	0.4 Nm
MDG 25 A 10	$\varnothing 25$	25	$+0.1$ -0.1	$\varnothing 10H7$	$+0.015$ 0	7	11	M4	8	9	0.4 Nm
MDG 30 A 10	$\varnothing 25$	30	$+0.1$ -0.1	$\varnothing 10H7$	$+0.015$ 0	8	14	M4	9	12	0.4 Nm

For proper installation it is recommended to insert shafts in the coupling observing "E" dimensions.



A series of 20 horizontal light blue bars spanning the width of the page, intended for writing notes.



Micro Detectors

Italian Sensors Technology

M.D. Micro Detectors S.p.A.
Strada S. Caterina 235
41122 Modena - Italy
tel. + 39 059 420411
fax + 39 059 253973
info@microdetectors.com
www.microdetectors.com

Micro Detectors Ibérica S.A.U.
c/. Antic Camí ral de València, 38
08860 - Castelldefels (Barcelona)
Tel.: +34 93 448 66 30
Fax: + 34 93 645 28 15
info@microdetectors.es
www.microdetectors.es

M.D. Micro Detectors
(Tianjin) Co., LTD.
XEDA International Industry
area B2-3 Xiqing District
300385 - Tianjin (China)
Tel.: +86 022 23471915
Fax: +86 022 23471913
info@microdetectors.com
www.microdetectors.com

ENGLISH ED. 01/2016